

# TRACTATENBLAD

VAN HET

KONINKRIJK DER NEDERLANDEN

---

---

JAARGANG 1970 Nr. 25

---

---

A. TITEL

*Verdrag inzake de visserij in het noordoostelijk deel  
van de Atlantische Oceaan, met bijlage;  
Londen, 24 januari 1959*

B. TEKST

De tekst van Verdrag en bijlage is geplaatst in *Trb.* 1959, 114.

C. VERTALING

Zie *Trb.* 1959, 114 en *Trb.* 1962, 127.

D. GOEDKEURING

Zie *Trb.* 1962, 127.

E. BEKRACHTIGING

Zie *Trb.* 1962, 127 en *Trb.* 1966, 149.

G. INWERKINGTREDING

Zie *Trb.* 1959, 114 en *Trb.* 1966, 149.

J. GEGEVENS

Zie *Trb.* 1959, 114, *Trb.* 1962, 127 en *Trb.* 1966, 149.

Op 12 september 1964 is te Kopenhagen tot stand gekomen een Overeenkomst betreffende de Internationale Raad voor het onderzoek van de zee. Tekst en vertaling van de Overeenkomst zijn geplaatst in *Trb.* 1966, 193. Zie ook *Trb.* 1968, 43.

In *Stb.* 312 is geplaatst de Wet van 30 mei 1963, houdende nieuwe regelen omtrent de visserij (Visserijwet). Deze wet is op 1 juni 1964 in werking getreden ingevolge Koninklijk besluit van 8 mei 1964 (*Stb.* 1964, 142).

In overeenstemming met artikel 7 van het Verdrag heeft de Visserijcommissie voor het noordoostelijk deel van de Atlantische Oceaan een aantal aanbevelingen vastgesteld.

Deze aanbevelingen welke voor Nederland verbindend zijn, zijn in de Nederlandse wetgeving verwerkt en wel bij Koninklijk besluit van 27 april 1964 (*Stb.* 160) (Besluit bescherming zeevissoorten 1964). Dit besluit is op 1 juni 1964 in werking getreden.

Tijdens de van 9 tot 12 mei 1967 te Parijs gehouden Vijfde Bijeenkomst, de van 7 tot 13 mei 1968 te Reykjavik gehouden Zesde Bijeenkomst en de van 7 tot 12 mei 1969 te Londen gehouden Zevende Bijeenkomst van de Visserijcommissie zijn vervolgens nog een drietal aanbevelingen vastgesteld, welke in de Nederlandse wetgeving zullen worden verwerkt. De tekst van deze aanbevelingen luidt als volgt:

*(Recommendation made by the North-East Atlantic Fisheries Commission at its Fifth Meeting held in Paris from 9th to 12th May 1967)*

### **Scheme of Joint Enforcement Recommendation**

Pursuant to Article 13 (3) of the Convention the Commission recommends the establishment of the following arrangements for international control outside territorial waters and fishery limits for the purpose of ensuring the application of the Convention and the measures in force thereunder:

(1) Control shall be carried out by inspectors of the fishery control services of Contracting States. The names of the inspectors appointed for that purpose by their respective governments shall be notified to the Commission.

(2) Ships carrying inspectors shall fly a special flag or pennant approved by the Commission to indicate that the inspector is carrying out international inspection duties. The names of the ships so used for the time being, which may be either special inspection vessels or fishing vessels, shall be notified to the Commission.

(3) Each inspector shall carry a document of identity supplied by the authorities of the flag state in a form approved by the Commission and given him on appointment stating that he has authority to act under the arrangements approved by the Commission.

(4) Subject to the arrangements agreed under paragraph (9), a vessel of any Contracting State employed for the time being in fishing for sea fish or in the treatment of sea fish in the Convention area shall stop when given the appropriate signal in the International Code of Signals by a ship carrying an inspector unless actually fishing, shooting or hauling, in which case it shall stop immediately it has finished hauling. The master of the vessel shall permit the inspector, who may be accompanied by a witness, to board it. The master shall enable the inspector to make such examination of catch, nets or other gear and any relevant documents as the inspector deems necessary to verify the observance of the Commission's recommendations in force in relation to the flag state of the vessel concerned and the inspector may ask for any explanations that he deems necessary.

(5) On boarding the vessel an inspector shall produce the document described in (3) above. Inspections shall be made so that the vessel suffers the minimum interference and inconvenience. An inspector shall limit his enquiries to the ascertainment of the facts in relation to the observance of the Commission's recommendations in force in relation to the flag state of the vessel concerned. In making his examination an inspector may ask the master for any assistance he may require. He shall draw up a report of his inspection in a form approved by the Commission. He shall sign the report in the presence of the master of the vessel who shall be entitled to add or have added to the report any observations which he may think suitable and must sign such observations. Copies of the report shall be given to the master of the vessel and to the Inspector's Government who shall transmit copies to the appropriate authorities of the flag state of the vessel and to the Commission. Where any infringement of the recommendations is discovered the inspector should where possible also inform the competent authorities of the flag state, as notified to the Commission, and any inspection ship of the flag state known to be in the vicinity.

(6) Resistance to an inspector or failure to comply with his directions shall be treated by the flag state of the vessel as if the inspector were an inspector of that state.

(7) Inspectors shall carry out their duties under these arrangements in accordance with the rules set out in this recommendation but they shall remain under the operational control of their national authorities and shall be responsible to them.

(8) Contracting States shall consider and act on reports of foreign inspectors under these arrangements on the same basis as reports of national inspectors. The provisions of this paragraph shall not impose any obligation on a Contracting State to give the report of a foreign inspector a higher evidential value than it would possess in the inspector's own country. Contracting States shall collaborate in order to facilitate judicial or other proceedings arising from a report of an inspector under these arrangements.

- (9) (i) Contracting States shall inform the Commission by 1st March each year of their provisional plans for participations in these arrangements in the following year and the Commission may make suggestions to Contracting States for the co-ordination of national operations in this field including the number of inspectors and ships carrying inspectors.
- (ii) The arrangements set out in this Recommendation and the plans for participation shall apply between Contracting States unless otherwise agreed between them; and such agreement shall be notified to the Commission: Provided, however, that implementation of the scheme shall be suspended between any two Contracting States, if either of them has notified the Commission to that effect, pending completion of an agreement.
- (10) (i) When nets are inspected the meshes of the cod-end are to be examined with a flat gauge with parallel sides, a thickness of 2 mm. and the appropriate width made of any durable material that will retain its shape and constructed with a wedge shaped section or sections having a taper of 2 cm. in 8 cm. calibrated to measure the width of the meshes in which the section or sections are inserted. An illustration of such a gauge is appended <sup>1)</sup>.
- (ii) The appropriate width is the appropriate width prescribed in the Commission's recommendations for the type of net inspected and the area in which the inspection takes place which are in force in relation to the flag state of the vessel concerned.
- (iii) At least 20 consecutive meshes of the cod-end running parallel to its long axis, starting at least ten meshes from the lacings, are to be examined, or the maximum number if less than 20.
- (iv) The gauge should be inserted into the meshes when wet so as to measure the long axis of the mesh when

---

<sup>1)</sup> Zie blz. 6 van dit *Tractatenblad*.

stretched diagonally lengthwise. If the section of the gauge with parallel sides passes easily through a mesh it is not undersized. If the inspector has any doubt as to whether the gauge passes easily through, he shall insert the gauge in the mesh held horizontally and attach a weight of 5 kilogrammes to the gauge and if the section in the gauge with parallel sides passes through the mesh the mesh is not undersized.

- (v) The number of undersized meshes and the width of each mesh examined shall be entered in the inspector's report, together with the average width of the meshes examined.
- (vi) Inspectors shall have authority to inspect all nets other than those which are dry and stowed away below deck.

(11) The inspector shall affix an identification mark approved by the Commission, to any net which appears to have been used in contravention of the Commission's recommendations in force in relation to the flag state of the vessel concerned and shall record this fact in his report.

(12) The inspector may photograph the net in such a way that the identification mark and the measurement of the net is visible, in which case the subjects photographed should be listed in the report and copies of the photographs should be attached to the copy of the report to the flag state.

(13) The inspector shall so far as reasonably practicable examine the catch and may take such measurements as he deems necessary to establish whether and to what extent undersized fish of protected species are present in the part of the catch inspected. He shall report his findings including the number of fish measured and the size of any fish which are undersized to the authorities of the flag state of the inspected vessel as soon as possible.

---

Paragraph (10) (i) Appendix  
Paragraphe (10) (i) Annexe

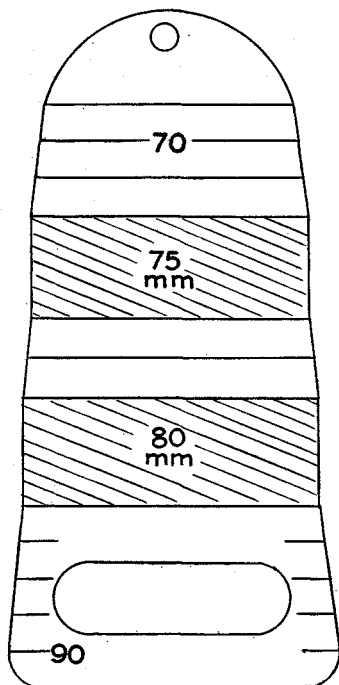

Illustration 1

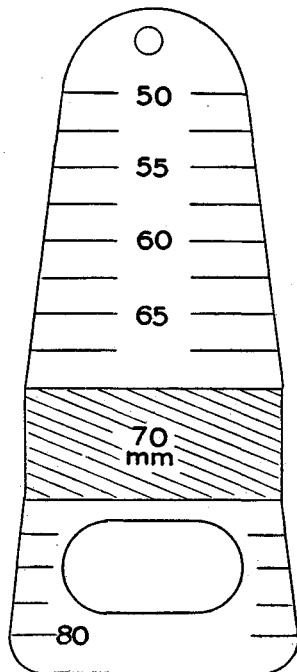

Illustration 2

*(Recommendation made by the North-East Atlantic Fisheries Commission at its Sixth Meeting held in Reykjavik from 7th to 13th May 1968)*

**Extension of the List of Species Specified  
in Recommendation (2)**

The Commission resolves that Recommendation (2) shall be amended as follows:

After the words "horse mackerel (*Trachurus trachurus*)" there shall be inserted the words "Polar cod (*Boreogadus saida*)".

*(Recommendation made by the North-East Atlantic Fisheries  
Commission at its Seventh Meeting held in London  
from 7th to 12th May 1969)*

### **Use of Topside Chafers**

The Commission recommends that:

Sub-paragraph (b) of Recommendation (3) shall be amended to read as follows:

“(b) Until 31st December, 1972, the Governments of Contracting States may, notwithstanding sub-paragraph (a) above authorise for trawl nets to which paragraph (a) of Recommendation (1) applies the attachment of chafers or covers to the upper side of the cod-ends of trawl nets for the purpose of preventing wear or tear, subject to such chafers or covers complying with one of the following specifications:

1. A piece of netting having in all its parts meshes the dimensions of which when measured wet are not less than those of the meshes of the net to which it is attached and provided that

- (i) it is fastened to the cod-end only along its forward and lateral edges
- (ii) its width is at least one and a half times the width of the part of the cod-end which is covered by it (such width being measured at right angles to the long axis of the cod-end) and
- (iii) if there is a splitting strop, it extends no more than four meshes forward of the splitting strop and ends not less than four meshes forward of the codline mesh, or  
if there is no splitting strop, it extends no more than one third of the length of the cod-end measured from not less than four meshes in front of the codline mesh.

2. Pieces of netting, having in all their parts, meshes the dimensions of which when measured wet are not less than those of the meshes of the net to which they are attached and provided that each piece of netting is:

- (i) fastened by its forward edge only across the cod-end at right angles to its long axis
- (ii) of a width of at least the width of the cod-end (such width being measured at right angles to the long axis of the cod-end at the point of attachment) and,

(iii) is not more than 10 meshes long; and the aggregate length of all the pieces of netting so attached does not exceed two thirds of the length of the cod-end.

3. A piece of netting, made of the same material as the cod-end, having in all its parts a mesh twice the mesh size of the cod-end when measured wet and fastened to the cod-end along the forward, lateral and rear edges only of the netting in such a way that each mesh of the netting coincides with four meshes of the cod-end."

---

Uitgegeven de vierde februari 1970.

*De Minister van Buitenlandse Zaken,*  
J. LUNS.